



SPARE PARTS EXPLODED VIEW GAS-WALL BOILER ATM. BURNER

Model

CARES XC - HS XC - EGIS XC

R8218623-04 - 13/07/2022

1	3301685	CARES XC 10 FF NG	02-2021	-
2	3301684	CARES XC 15 FF NG	02-2021	-
3	3301683	CARES XC 18 FF NG	02-2021	-
4	3301682	CARES XC 24 FF NG	02-2021	-
5	3301689	HS XC 10 FF NG	03-2021	-
6	3301688	HS XC 15 FF NG	03-2021	-
7	3301687	HS XC 18 FF NG	03-2021	-
8	3301686	HS XC 24 FF NG	03-2021	-
9	3302267	EGIS XC 15 FF NG	04-2022	-
10	3302266	EGIS XC 24 FF NG	04-2022	-

Col	Reference	Model type	Begin	End
-----	-----------	------------	-------	-----

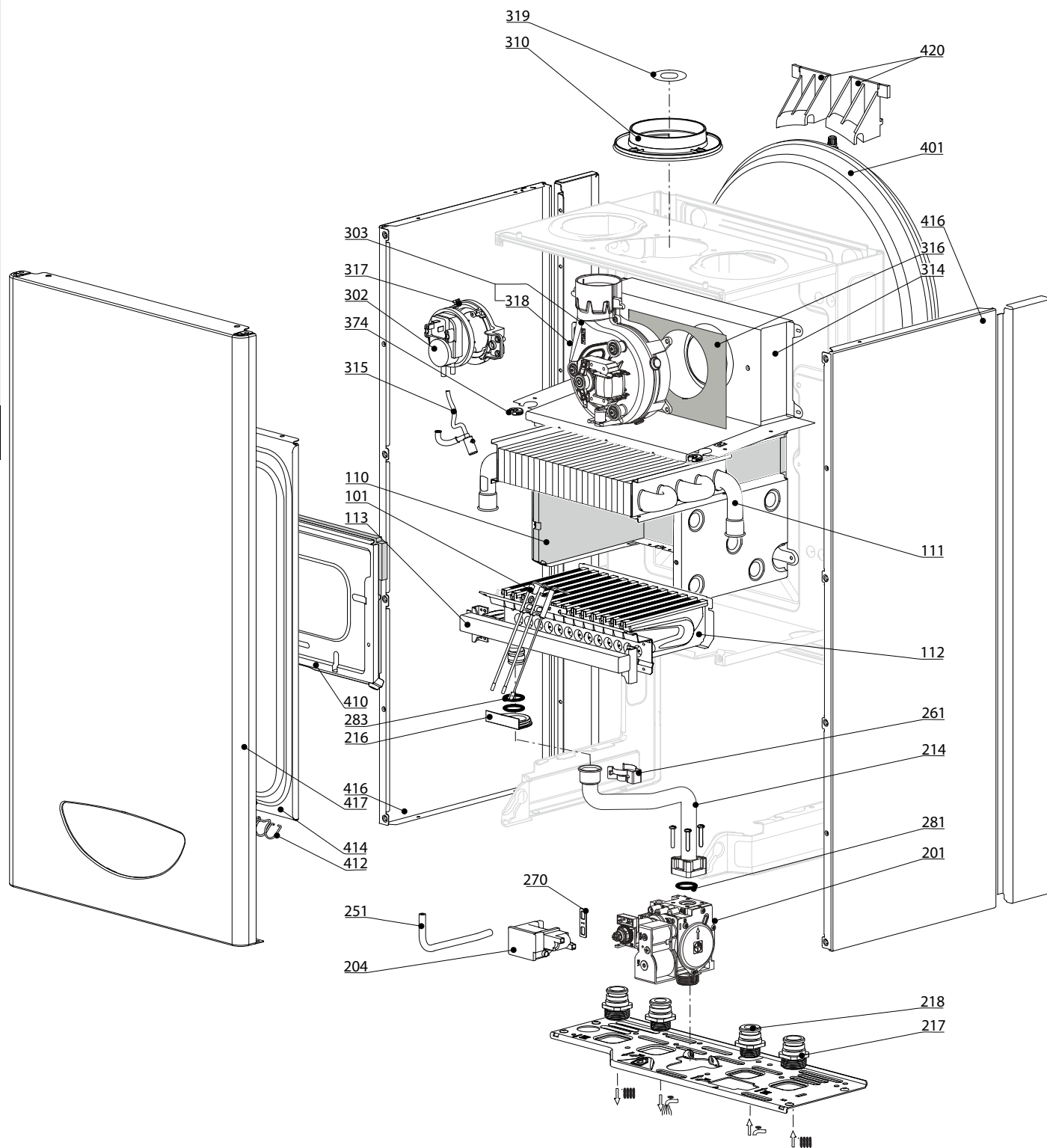

☉⇒	Description	Manf. Pt. N	Type	<div style="display: flex; justify-content: space-between; font-size: small;"> CARES-XC-10-FF-NG CARES-XC-15-FF-NG CARES-XC-18-FF-NG CARES-XC-24-FF-NG HS-XC-10-FF-NG HS-XC-15-FF-NG HS-XC-18-FF-NG EGIS-XC-24-FF-NG EGIS-XC-15-FF-NG EGIS-XC-24-FF-NG </div>																		From	to
				1	2	3	4	5	6	7	8	9	10	11	12	13	14	15	16	17	18		
0100	BURNER ASSEMBLY																						
0101	ЭЛЕКТРОДЫ РОЗЖИГА ИОНИЗАЦИИ	65115802		●	●	●	●	●	●	●	●	●	●	●	●	●	●	●	●				
0110	ТЕПЛОИЗОЛЯЦИЯ (КОМПЛЕКТ)	65106298		●	●	●	●	●	●	●	●	●	●	●	●	●	●	●	●				
0111	ОСНОВНОЙ ТЕПЛООБМЕННИК (Cu)	65120314		●	●	●	●	●	●	●	●	●	●	●	●	●	●	●	●				
	ОСНОВНОЙ ТЕПЛООБМЕННИК (Cu)	65106297																					
0112	ГОРЕЛКА 11NP	65106294		●	●	●	●	●	●	●	●	●	●	●	●	●	●	●	●				
0113	ГАЗОВЫЙ КОЛЛЕКТОР 11 INJ. D:1.32	65106302	G20	●	●	●	●	●	●	●	●	●	●	●	●	●	●	●	●				
0200	GAS SECTION																						
0201	ГАЗОВЫЙ КЛАПАН	65115771		●	●	●	●	●	●	●	●	●	●	●	●	●	●	●	●				
0204	БЛОК РОЗЖИГА	65115791-01		●	●	●	●	●	●	●	●	●	●	●	●	●	●	●	●				
0214	ПАТРУБОК (ГАЗОВЫЙ КЛАПАН/ГОРЕЛКА)	65115772		●	●	●	●	●	●	●	●	●	●	●	●	●	●	●	●				
0216	УПЛОТНЕНИЕ	60000624		●	●	●	●	●	●	●	●	●	●	●	●	●	●	●	●				
0217	СН СОЕДИНЕНИЕ 3/4"	65114929		●	●	●	●	●	●	●	●	●	●	●	●	●	●	●	●				
0218	DWN СОЕДИНЕНИЕ 1/2"	65114930		●	●	●	●	●	●	●	●	●	●	●	●	●	●	●	●				
0251	ТРУБКА EPDM	65115773		●	●	●	●	●	●	●	●	●	●	●	●	●	●	●	●				
0261	КЛИПСА	60001861		●	●	●	●	●	●	●	●	●	●	●	●	●	●	●	●				
0270	ПРОКЛАДКА БЛОКА РОЗЖИГА	574279		●	●	●	●	●	●	●	●	●	●	●	●	●	●	●	●				
0281	О-КОЛЬЦО 22.22X2.62	65104304		●	●	●	●	●	●	●	●	●	●	●	●	●	●	●	●				
0283	О-КОЛЬЦО 17.17X1.78	65104303		●	●	●	●	●	●	●	●	●	●	●	●	●	●	●	●				
0300	FAN ASSEMBLY																						
0302	ПНЕВМОРЕЛЕ 50 Pa	65104671-01		●	●	●	●	●	●	●	●	●	●	●	●	●	●	●	●				
0303	ВЕНТИЛЯТОР 24 KW	65121235		●	●	●	●	●	●	●	●	●	●	●	●	●	●	●	●				
0310	ПАТРУБОК ПРИТОКА ВОЗДУХА	65115914		●	●	●	●	●	●	●	●	●	●	●	●	●	●	●	●				
0314	КАМЕРА СГОРАНИЯ 24 FF	65115800		●	●	●	●	●	●	●	●	●	●	●	●	●	●	●	●				
0315	КОНДЕНСАТООТВОДЧИК	65105349		●	●	●	●	●	●	●	●	●	●	●	●	●	●	●	●				
0316	ТЕПЛОИЗОЛЯЦИЯ ВЕНТИЛЯТОРА	65104305		●	●	●	●	●	●	●	●	●	●	●	●	●	●	●	●				
0317	КРОНШТЕЙН ПНЕВМОРЕЛЕ	65115812		●	●	●	●	●	●	●	●	●	●	●	●	●	●	●	●				
0318	ТРУБКА ВЕНТУРИ 15/24 FF	65106516		●	●	●	●	●	●	●	●	●	●	●	●	●	●	●	●				
0319	ДИАФРАГМА (KIT)	60001598		●	●	●	●	●	●	●	●	●	●	●	●	●	●	●	●				
0374	УПЛОТНЕНИЕ ДЛЯ КАБЕЛЯ	60000716		●	●	●	●	●	●	●	●	●	●	●	●	●	●	●	●				
0400	SEALED CASE																						
0401	РАСШИРИТЕЛЬНЫЙ БАК 8Л	65104261		●	●	●	●	●	●	●	●	●	●	●	●	●	●	●	●				
0410	ПАНЕЛЬ КАМЕРЫ СГОРАНИЯ	65106296		●	●	●	●	●	●	●	●	●	●	●	●	●	●	●	●				
0412	ПРУЖИНА ПЕРЕДНЕЙ ПАНЕЛИ (KIT)	65107048		●	●	●	●	●	●	●	●	●	●	●	●	●	●	●	●				
0413	ЗАГЛУШКА ПОДАЧИ ВОЗДУХА	65104249						●	●	●	●	●	●	●	●	●	●	●	●				
0414	ГЕРМЕТИЗИРУЮЩАЯ КРЫШКА	65105678-02		●	●	●	●	●	●	●	●	●	●	●	●	●	●	●	●				
0416	ПАНЕЛЬ КОРПУСА (ЛЕВАЯ + ПРАВАЯ) - WHITE	65115804		●	●	●	●	●	●	●	●	●	●	●	●	●	●	●	●				
0417	ПАНЕЛЬ КОРПУСА (ПЕРЕДНЯЯ)	65115823		●	●	●	●	●	●	●	●	●	●	●	●	●	●	●	●				
	ПАНЕЛЬ КОРПУСА (ПЕРЕДНЯЯ)	65115824						●	●	●	●	●	●	●	●	●	●	●	●				
0420	КРОНШТЕЙН РАСШИРИТЕЛЬНОГО БАКА	65104696		●	●	●	●	●	●	●	●	●	●	●	●	●	●	●	●				

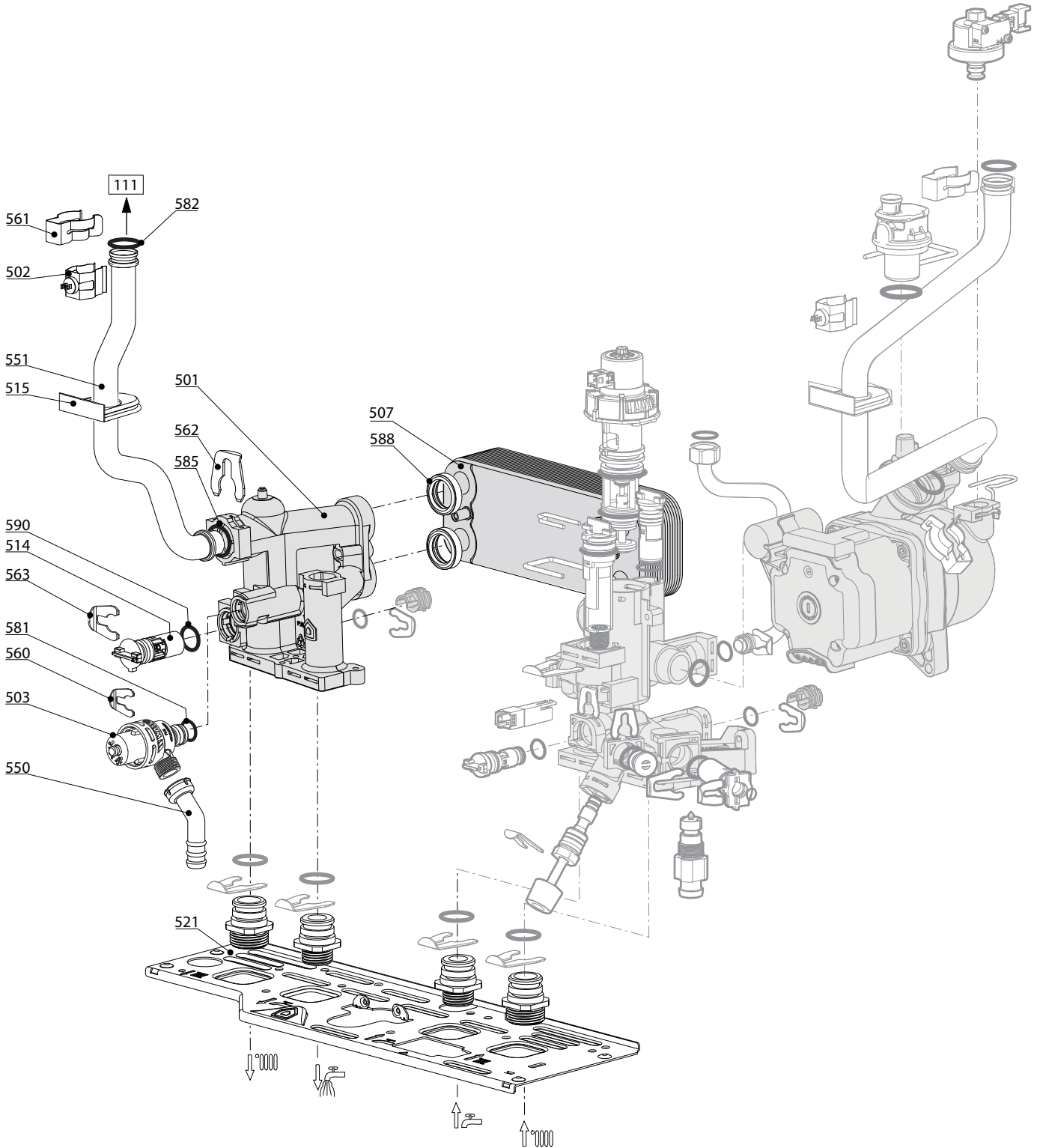

☉⇒	Description	Manf. Pt. N	Type	<div style="display: flex; justify-content: space-between; font-size: small;"> CARES XC 10 FF NG CARES XC 15 FF NG CARES XC 18 FF NG HS XC 10 FF NG HS XC 15 FF NG HS XC 18 FF NG EGIS XC 24 FF NG EGIS XC 15 FF NG EGIS XC 24 FF NG </div>																		From	to
				1	2	3	4	5	6	7	8	9	10	11	12	13	14	15	16	17	18		
0500	FLOW GROUP																						
0501	ГРУППА ПОДАЧИ	65117952		●	●	●	●	●	●	●	●	●	●	●	●	●	●	●	●				
0502	ДАТЧИК ТЕМПЕРАТУРЫ + КЛИПСА	990686-01		●	●	●	●	●	●	●	●	●	●	●	●	●	●	●	●				
0503	ПРЕДОХРАНИТЕЛЬНЫЙ КЛАПАН (3 БАРА)	61312668		●	●	●	●	●	●	●	●	●	●	●	●	●	●	●	●				
0507	ТЕПЛООБМЕННИК ГВС (16 ПЛАСТИН)	65104333		●	●	●	●	●	●	●	●	●	●	●	●	●	●	●	●				
0514	БАЙПАС	65114917		●	●	●	●	●	●	●	●	●	●	●	●	●	●	●	●				
0515	УПЛОТНЕНИЕ	60000808		●	●	●	●	●	●	●	●	●	●	●	●	●	●	●	●				
0521	ОСНОВАНИЕ ГИДРАВЛИЧЕСКОЙ ГРУППЫ	65115797		●	●	●	●	●	●	●	●	●	●	●	●	●	●	●	●				
0550	ПАТРУБОК ПРЕДОХРАНИТЕЛЬНОГО КЛАПАНА	60001955		●	●	●	●	●	●	●	●	●	●	●	●	●	●	●	●				
0551	ТРУБКА ПОДАЧИ ТЕПЛОНОСИТЕЛЯ (Cu)	65115915		●	●	●	●	●	●	●	●	●	●	●	●	●	●	●	●				
0560	КЛИПСА D:10	65114933		●	●	●	●	●	●	●	●	●	●	●	●	●	●	●	●				
0561	КЛИПСА	61307589		●	●	●	●	●	●	●	●	●	●	●	●	●	●	●	●				
0562	КЛИПСА D:18	65104259		●	●	●	●	●	●	●	●	●	●	●	●	●	●	●	●				
0563	КЛИПСА D:12	65114932		●	●	●	●	●	●	●	●	●	●	●	●	●	●	●	●				
0581	O-КОЛЬЦО 17.96X2.62	65104337		●	●	●	●	●	●	●	●	●	●	●	●	●	●	●	●				
0582	O-КОЛЬЦО 17.86X2.62	61308091		●	●	●	●	●	●	●	●	●	●	●	●	●	●	●	●				
0585	O-КОЛЬЦО 17.04X3.53	65104262		●	●	●	●	●	●	●	●	●	●	●	●	●	●	●	●				
0588	ПРОКЛАДКА ТЕПЛООБМЕННИКА	65114928		●	●	●	●	●	●	●	●	●	●	●	●	●	●	●	●				
0590	O-КОЛЬЦО 11.91X2.62	65114940		●	●	●	●	●	●	●	●	●	●	●	●	●	●	●	●				

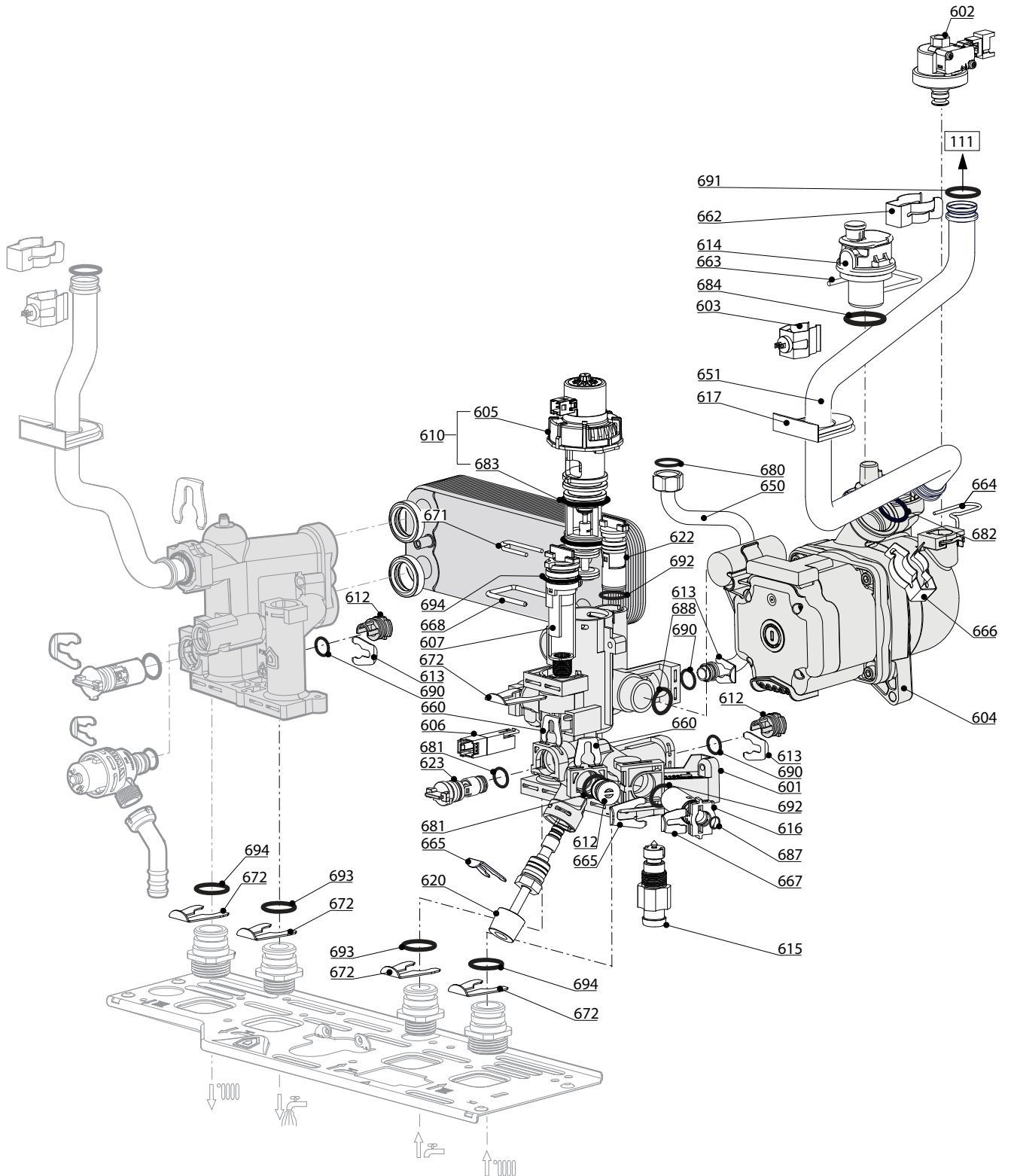

800

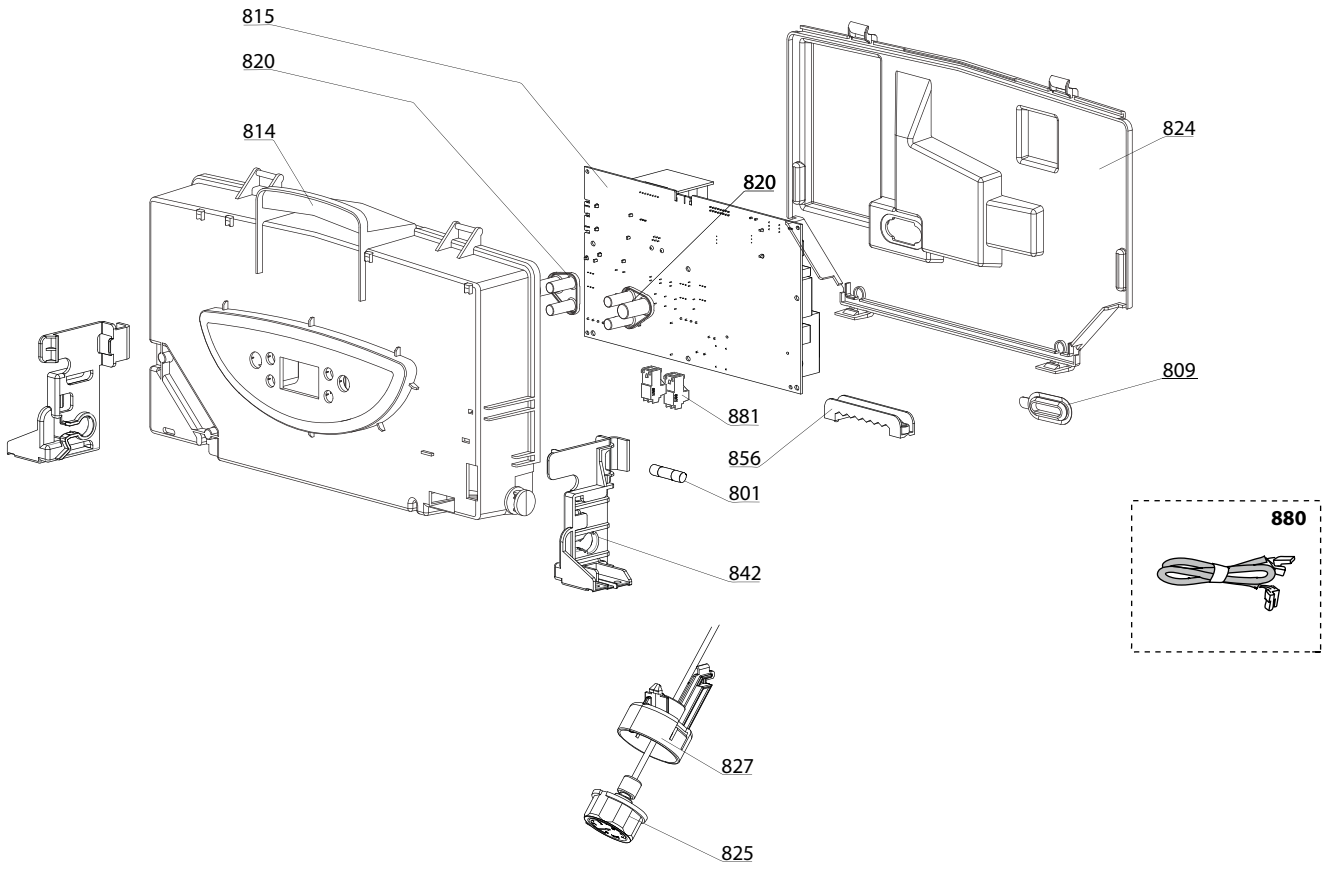

900

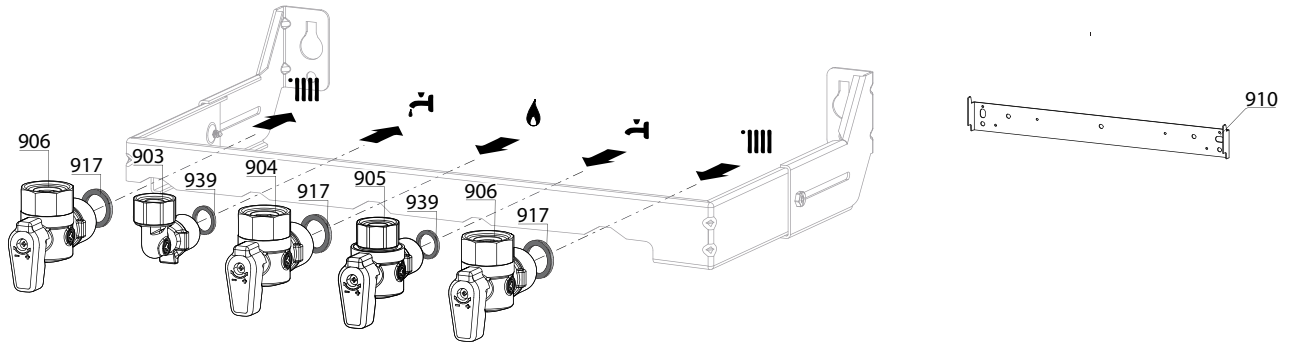

5000

5001
 Transf. gaz
 Conv. gaz
 Trsf. gas
 Transf. gas
> G31
 (LPG - GPL)

5002
 Transf. gaz
 Conv. gaz
 Trsf. gas
 Transf. gas
> G20
 (NAT - MET)

☉⇒	Description	Manf. Pt. N	Type	<div style="display: flex; justify-content: space-between; font-size: small;"> CARES XC 10 FF NG CARES XC 15 FF NG CARES XC 18 FF NG HS XC 10 FF NG HS XC 15 FF NG HS XC 18 FF NG EGIS XC 24 FF NG EGIS XC 15 FF NG EGIS XC 24 FF NG </div>																		From	to
				1	2	3	4	5	6	7	8	9	10	11	12	13	14	15	16	17	18		
0800	ELECTRICAL BOX																						
0801	ПРЕДОХРАНИТЕЛЬ 5X20 RIT. 2A 250V	65112137		●	●	●	●	●	●	●	●	●	●	●	●	●	●	●	●				
0809	ЗАГЛУШКА (PCD TOOL ACCESS)	998382		●	●	●	●	●	●	●	●	●	●	●	●	●	●	●	●				
0814	КОРПУС БЛОКА УПРАВЛЕНИЯ (FRONT)	65120328		●	●	●	●																
	КОРПУС БЛОКА УПРАВЛЕНИЯ (FRONT)	65120456						●	●	●	●	●	●	●	●	●	●	●	●				
0815	ОСНОВНАЯ ПЛАТА + ДИСПЛЕЙ	65115782-05		●	●	●	●	●	●	●	●	●	●	●	●	●	●	●	●				
0820	КНОПКА УПРАВЛЕНИЯ	65120327		●	●	●	●	●	●	●	●	●	●	●	●	●	●	●	●				
0824	КОРПУС БЛОКА УПРАВЛЕНИЯ (REAR)	65121095		●	●	●	●	●	●	●	●	●	●	●	●	●	●	●	●				
0825	МАНОМЕТР (0-4 БАР)	65114200		●	●	●	●	●	●	●	●	●	●	●	●	●	●	●	●				
0827	КРОНШТЕЙН МАНОМЕТРА	65115809		●	●	●	●	●	●	●	●	●	●	●	●	●	●	●	●				
0842	БОКОВОЙ ФИКСАТОР ПАНЕЛИ УПРАВЛЕНИЯ	65115811		●	●	●	●	●	●	●	●	●	●	●	●	●	●	●	●				
0856	ЗАЖИМ ДЛЯ КАБЕЛЯ	65103377		●	●	●	●	●	●	●	●	●	●	●	●	●	●	●	●				
0880	КАБЕЛЬ 3-Х ХОДОВОГО КЛАПАНА	65115790		●	●	●	●	●	●	●	●	●	●	●	●	●	●	●	●				
	КАБЕЛЬ ЭЛЕКТРОДА ИОНИЗАЦИИ	60001883		●	●	●	●	●	●	●	●	●	●	●	●	●	●	●	●				
	КАБЕЛЬ НАСОСА 5М 1V	65153612		●	●	●	●	●	●	●	●	●	●	●	●	●	●	●	●				
	КАБЕЛЬ ЗАЗЕМЛЕНИЯ	65104286		●	●	●	●	●	●	●	●	●	●	●	●	●	●	●	●				
	КАБЕЛЬ ПИТАНИЯ 240V	60001619		●	●	●	●	●	●	●	●	●	●	●	●	●	●	●	●				
	КАБЕЛЬ ДАТЧИК ТЕМП. - ПНЕВМОРЕЛЕ	65115789		●	●	●	●	●	●	●	●	●	●	●	●	●	●	●	●				
0881	КОННЕКТОР 2P	65111933		●	●	●	●	●	●	●	●	●	●	●	●	●	●	●	●				
	КОННЕКТОР 3P (x5)	65111934-01		●	●	●	●	●	●	●	●	●	●	●	●	●	●	●	●				
0900	JIG PLATE & PIPE FITTING																						
0903	ПАТРУБОК ГВС	60000891		●	●	●	●	●	●	●	●	●	●	●	●	●	●	●	●				
0904	КРАН ГАЗА	65120204		●	●	●	●	●	●	●	●	●	●	●	●	●	●	●	●				
0905	КРАН ХОЛОДНОЙ ВОДЫ	60000894		●	●	●	●	●	●	●	●	●	●	●	●	●	●	●	●				
0906	КРАН ПОДАЧИ/ВОЗВРАТА ТЕПЛОНОСИТЕЛЯ	60000885		●	●	●	●	●	●	●	●	●	●	●	●	●	●	●	●				
0910	КРОНШТЕЙН	60000625		●	●	●	●	●	●	●	●	●	●	●	●	●	●	●	●				
0915	ПРОКЛАДКА КРАНА ГАЗА	65119354		●	●	●	●	●	●	●	●	●	●	●	●	●	●	●	●				
0917	ПЛОСКАЯ ПРОКЛАДКА D:24-17-1.5	60061855-19		●	●	●	●	●	●	●	●	●	●	●	●	●	●	●	●				
0939	ПЛОСКАЯ ПРОКЛАДКА D:18.4-12.2-1.5	60061855-14		●	●	●	●	●	●	●	●	●	●	●	●	●	●	●	●				
5000	ACCESSORIES																						
5001	К-Т ПЕРЕВОДА НА СЖИЖЕННЫЙ ГАЗ (LPG)	65104582-01		●	●	●	●	●	●	●	●	●	●	●	●	●	●	●	●				
5002	К-Т ПЕРЕВОДА НА ПРИРОДНЫЙ ГАЗ (NG)	65104583-01		●	●	●	●	●	●	●	●	●	●	●	●	●	●	●	●				

LIST OF THE ABBREVIATIONS

HW	: Hot water.
CW	: Cold water.
C	: Ceramic resistance (normal heating).
Ca	: Ceramic resistance (accelerated heating)
TP	: Immersion heater.
1F	: With fittings.
2F	: Without fittings.
3F	: With fittings and another outlet connection.
AMI	: With mixing valve.
SMI	: Without mixing valve.
PUISS	: Power of th appliance.
PN	: Appliance with normal pression.
LP	: Appliance with low pression.
PV	: Appliance with variable power.
PF	: Appliance with fixed power.

IDENTIFICATION PLATE

SERIAL NUMBER

10 Characters :	04 05 125 011	Sequential number Manufacturing day Year of manufacture
11 Characters :	1 95 065004 - 31	Technical number of the appliance Sequential number Year of manufacture
Month of manufacture : from 1 to 9 → Jan. to Sep., O → Oct., N → Nov., D → Dec.		
19 Characters :	08 05 0013199 900640031	Product reference Sequential number
Year of manufacture Month of manufacture		
20 Characters :	3675007 XX 2 07 070 00315	Sequential number Manufacturing day Year of manufacture
Product reference Millenium of manufacture		
21 Characters :	3675007 XX 07 070 0000315	Sequential number Manufacturing day
Product reference Year of manufacture		